

Elevated Foundations

New flood elevations set by FEMA require many houses built in coastal areas to be raised between 2' and 14' or more above grade, depending on local topography and risk exposure. Local homeowners who build houses on elevated foundations should choose a system that resists wind uplift and lateral forces, is easily constructed, and allows water to pass beneath the finished house. Depending on the required flood elevation, several systems may be appropriate. Profiled foundation systems include driven wood piles; wood posts with concrete grade beam; CMU piers; stem walls; and poured concrete piers. Homeowners with extreme sites, such as those in a FEMA-designated V Zone, and sites requiring elevation of above 14', must consult engineers for specific designs that account for these additional risks.

Driven Wood Piles

Driven wood piles are long timbers that are driven into the soil by a pneumatic hammer until detected resistance indicates they have reached an acceptable bearing capacity. Driven piles are a simple, quick, and relatively affordable choice for elevated housing. The wood is easily notched to receive joists, and no concrete is needed. They are also unaffected structurally by scour, which is a concern in flood zones.

Wood Piers with Concrete Grade Beam

When pile driving is financially or practically impossible, or the site is too remote for pile-driver access, homeowners may choose wood piers with a concrete grade beam. In this system, an auger is used to dig holes and hold long wooden piers in place using a system of concrete, rebar, and a grade beam. This system must be detailed precisely in order to resist hurricane forces, and may require a significant amount of concrete, potentially making the foundation system more costly than driven piles.



(FIG.A) DRIVEN WOOD PILES are a quick and straightforward foundation system, but must be installed professionally.



(FIG.B) CMU PIERS bear on a continuous footing and are grouted with rebar to resist uplift forces.



(FIG.C) POURED CONCRETE PIERS can either extend to the floor system rim joist (left), or connect to intermediate wood piers (right).

foundations	construction process	speed	delivery method	required equipment	specialized labor	wind resistance	water resistance	fire resistance	thermal performance	life span	environmental impact	product versatility	market exposure	code approval	affordability	coastal considerations
driven wood piles	+	+		-	-	+	+					+	+	-	+	+
wood posts with concrete grade beam			+	+	+		+							-		
cmu piers			-	+		-	-	+					+			-
stem walls			+	+		-	-	+				-		-	+	-
poured concrete piers		-	+	+	-	+	+	+		+		+	+		-	+

CMU Piers

Concrete Masonry Units (CMU) are modular concrete blocks that can be stacked to the required height. The CMU piers, which bear on a continuous concrete footing, are reinforced with vertical rebar and grout. Anchor bolts are cast into the top of the pier to securely fasten the floor system to the foundation. CMU piers should only be used for houses elevated less than a full story.

Stem Walls

Stem walls are made of CMU or ICF, but in continuous joist-bearing walls rather than piers. In cases where the stem wall is low enough, the entire interior is backfilled, and a slab poured across the surface. Stem walls are not appropriate for FEMA-rated Flood Zones or sites requiring elevation above 4'.

Poured Concrete Piers

Poured concrete piers are cast-in-place piers connected by a continuous footing or grade beam. A poured concrete pier system with a continuous grade beam or slab and concrete piers extending below grade, is very strong. The large quantities of steel and concrete required make it considerably more expensive than other foundation systems. If the homeowner is in a V-zone or coastal A-zone, or is required to build more than 10' above grade, this system may be advisable.

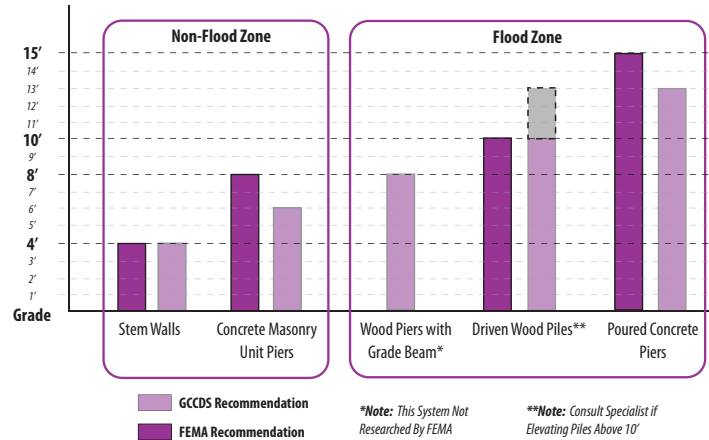

(FIG. D) RECOMMENDED ELEVATION HEIGHTS for each profiled foundation system.

FURTHER INFORMATION

Recommended Residential Construction for the Gulf Coast: Building on Strong and Safe Foundations, July 2006, FEMA. Available at <http://www.fema.gov/library/viewRecord.do?id=1853>

GCCDS: <http://www.gccds.org/>

OTHER TYPES OF ELEVATED FOUNDATIONS

5

ELEVATED FOUNDATIONS

subjects

5.1	Driven Wood Piles
5.2	Wood Piers with Concrete Grade Beam
5.3	Concrete Masonry Unit Piers
5.4	Stem Walls
5.5	Poured Concrete Piers

ELEVATED FOUNDATIONS

OVERVIEW: New flood elevations set by FEMA through the National Flood Insurance Program now require many houses built in coastal areas to elevate their finished floor between 2' and 14' or more above grade, depending on local topography and risk exposure. As a result, local homeowners are struggling to understand the variables related to elevated foundations.

Based on engineer and contractor advice as well as personal experience, and referencing FEMA's July 2006 Publication, *Recommended Residential Construction for the Gulf Coast*, GCCDS has developed this overview of the most common and affordable options for elevated foundations.

The foundation systems profiled here are not the only systems available, merely those that we find to be most appropriate across the widest variety of sites. Extreme sites, such as those in a FEMA-designated V Zone and sites requiring elevation of above 14', are not discussed in this overview. In those instances, homeowners should consult engineers for design solutions that fully account for these additional risk factors. FEMA's publication *Recommended Residential Construction for the Gulf Coast*, contains additional foundation alternatives.

DESIGN CONSIDERATIONS: Elevated foundations create design opportunities and challenges. Elevating a full story above grade creates usable, shaded, outdoor space beneath the house, and can be utilized for parking or a screened room. Some cities or municipalities along the coast will allow small enclosed shed spaces below the finished floor elevation. Some homeowners pour concrete pads at grade under their houses in order to create a permanently shaded patio, which can be especially desirable during hot summers.

Another benefit of elevating houses comes in flood insurance savings. The National Flood Insurance Program (NFIP), which is administered through FEMA, offers flood insurance to homeowners in a designated A or V flood zone. Each additional foot elevated above the required finished floor elevation reduces the insurance rate, up to 65% annually at the maximum additional height of 3'. See Appendix I, "Insuring Homes," for further information.

Elevated housing is not well suited to homeowners who have mobility or accessibility concerns, however. Many elderly or disabled homeowners have difficulty climbing stairs. In some cases, handicapped ramps can reduce the difficulty of getting up to the final floor elevation, but ramps, with their maximum slope of 1:12, can become very long when designed for high houses. Other options include elevators and handicapped lifts. Check with manufacturers for maximum heights and pricing. In extreme cases, a concerned homeowner with a low-lying lot requiring high elevation should think about selling the lot and purchasing another on higher ground.

Care should also be taken to include more than one entrance to elevated homes for egress in case of fires. Window egress often opens onto vertical drops of a full story, so having a separate entrance can increase safety. High houses can also make inhabitants feel claustrophobic or removed from the street. Access to outdoor decks or porches at the finished flood elevation often helps elevated houses feel comfortable and pleasant.

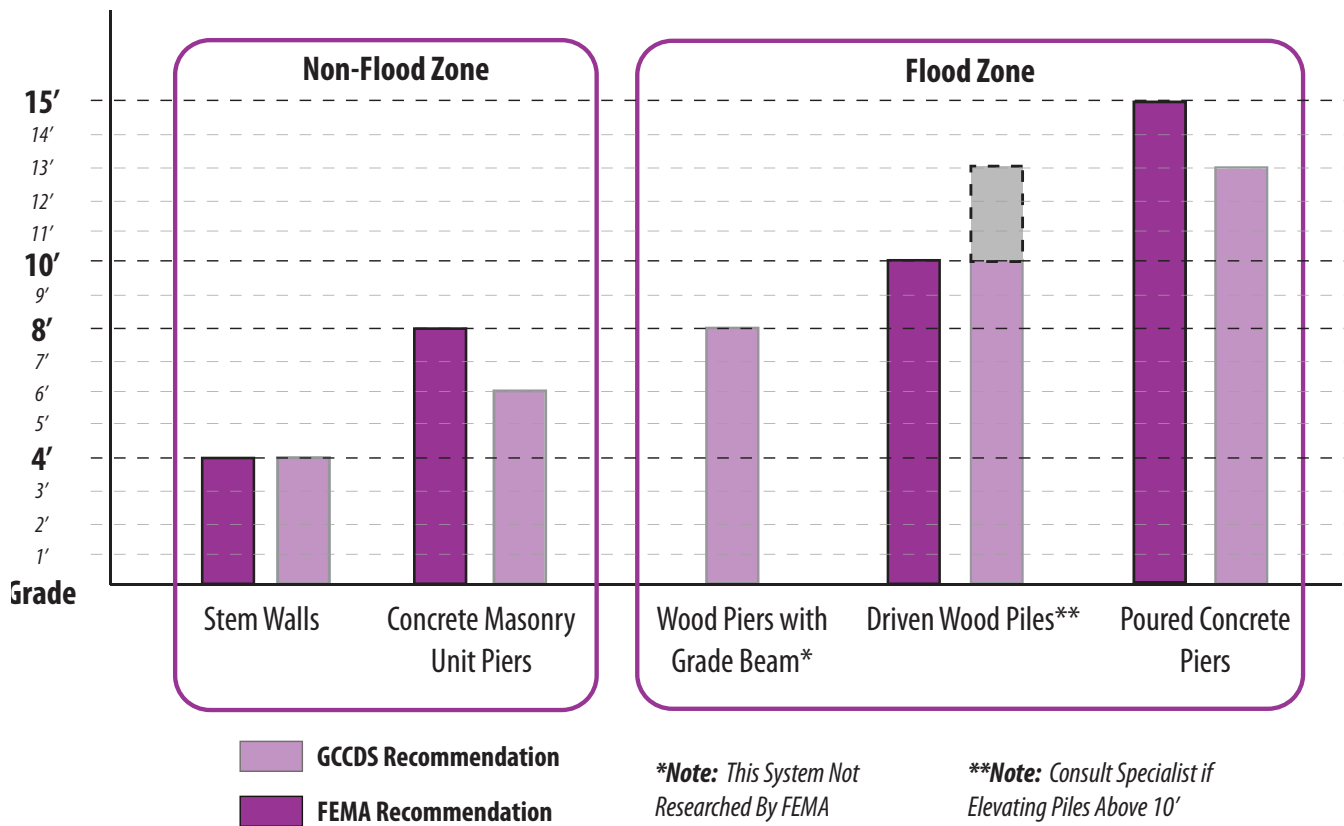

(Fig. 1) Recommended foundation systems, when properly engineered, according to height above grade. (FEMA and GCCDS)

Driven Wood Piles

Overview: Wood piles are lengths of CCA pressure-treated timber, either round or square in section, that are driven into the soil by pneumatic or hydraulic hammers until the timbers reach an acceptable bearing capacity. Rather than bearing on a single point, the piles “rely primarily on the friction forces that develop between the pile and the surrounding soils (to resist gravity and uplift forces) and the compressive strength of the soils (to resist lateral movement)”¹. Driven piles can also be made of steel pipes or precast concrete, but neither is used frequently in coastal residential construction.

When driven to an appropriate depth, they are also resistant to scour, which is a type of erosion that happens during flood events. Water rushing by erodes the soil at the base of the piles, creating scooped-out depressions. Scour can undermine shallow foundations such as slabs or even piers with continuous footings. In contrast, wooden piles driven to sufficient depths still retain enough resistance and bearing capacity that scour is no longer a structural concern.²

Generally, piles are driven into the soil at least as far below as they extend above - for example, a pile for a house elevated 10' above grade should be driven at least 10' below grade. A small, 24' x 40' house requires approximately 15 piles in order to adequately support its floor framing system.

Driven piles are a simple, quick, and relatively affordable choice for elevated housing; the wood is easily notched to receive joists, and no concrete is needed. However, they are subject - as any other foundation is - to damage from flood-borne debris, and it is nearly impossible to replace or repair individual piles once damaged.

INSTALLATION

Construction Process: Timber is brought to the site from lumber yards and is driven by professionals. Once driven to bearing capacity, piles are immediately ready for

rim joists to be bolted to the top. After piles are set and driven, however, there is no way to reposition them, so accuracy is essential.

The professional pile driver lifts timbers into position vertically and uses a hydraulic or pneumatic system to lift a hammer and drop it repeatedly onto the top of the timber. The number of hammer blows required to pound the timber into place is indicative of the bearing capacity of the pile in the soil. For this reason, local officials may request a copy of the blow counts to ensure proper foundational support.

Speed of Construction: An average house with 15 piles, 10' below the soil and 10' above, can be driven by a professional pile driver in as little as a single day.

Delivery Method: Piles are purchased from a regional lumber yard and brought by truck to the job site. A truck with pile driving machinery is set up to stand piles upright at their final position, and then a hammer gradually pounds the pile into the ground.

Required Equipment: Professional pile driving equipment: a boom truck to lift timbers and a hydraulic or pneumatic hammer driver. A chain saw or circular saw is often used to cut piles to the same finish level, and to notch piles to receive rim joists.

Specialized Labor: Professional pile drivers.



(Fig. 2) Professionals keep the timber in place while the pile-driving hammer drives it down.

PERFORMANCE

Wind Load: Piles are securely held in the ground through soil friction, but because the structure is elevated there will be some sway in the final structure. A good rule of thumb: if the house is elevated fewer than 6' above grade, 8x8 piles can be used; if the house is elevated more than 6' above grade, 10x10 piles should be used. The extra mass of 10x10 piles stiffens the pile against wind sway. Additionally, the piles should be cross-braced to resist racking.

Water Resistance: CCA-treated wood piles are resistant to water damage, flood scour, and rot. CCA-treated piles are also resistant to termite damage. Do not use any other form of treatment.

Energy/Thermal: No special thermal performance.

Life Span: CCA-treated wood piles are often warranted for 40 years, but often last as long as 75.³

Common Failure: If not cross-braced properly, the piles could rack and tip diagonally, affecting the finished floor platform.

DESIGN

Environmental Impact: CCA is toxic but is present in low enough quantities to not affect nearby soil or water. Timbers can be procured from a renewable, responsibly managed source.

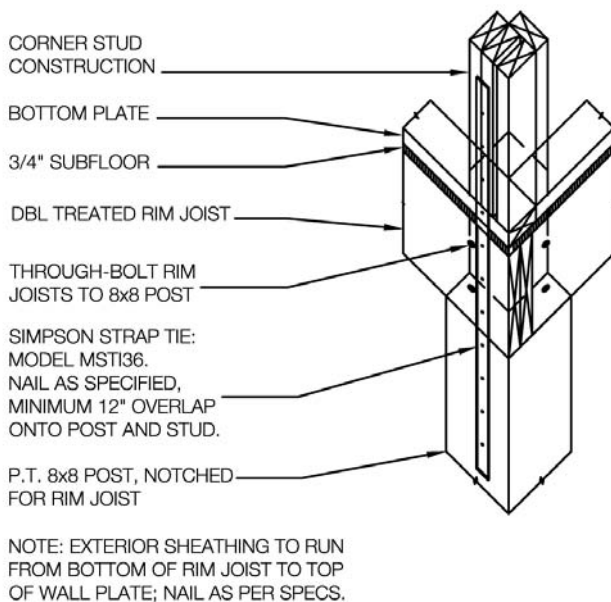

(Fig. 3) Detail drawing of the connection and strapping between the floor system and the driven wooden pile.

Versatility / Flexibility: Wood piles can be used for housing elevated to a standard 18" crawlspace, or as high as 10' above grade. For houses elevated above 10', FEMA discourages the use of driven piles. Doubled 2x12 rim joists bolted to 10x10 piles can span 10' comfortably. House plans should align piles for simpler floor framing construction.

Market Exposure: Wood piles are ubiquitous along the Gulf Coast.

Code Approval: Driven piles are increasingly but tentatively approved by local building inspectors. The professional pile driver will keep track of the blow count, which tells him how much bearing capacity the soil has, and this document is approved by the city. Some cities require an architect or engineer to sign this document as well. Check with your municipality's building division before committing to piles.

Affordability: Wood piles are currently the least expensive option for elevated foundation housing. Driven piles for a 24' x 40' home elevated 8' above grade can cost as little as \$7000 for lumber and labor.

GULF COAST AVAILABILITY / LOCAL MANUFACTURERS

Professional pile drivers work along the Gulf Coast, using lumber from local yards. Many specialize in marine or industrial applications, so homeowners should check for residential providers.

- NTC Pile Driving Services, Ocean Springs, MS.



(Fig. 4) A house elevated on driven wood piles.

Wood Piers with Concrete Grade Beam

Overview: Occasionally wood piles cannot be driven due to a lack of available labor or constrictive site conditions. The homeowner may still desire foundations made of wood for its tensile strength. At the same time, unstable or exceedingly wet soil conditions may make a foundation with a shallow concrete footing inadvisable. In these cases, a hybrid system combining elements of driven wood piles and a poured concrete pier system may be an appropriate solution.

Instead of a shallow, continuous concrete footing that piers rest on, individual holes are dug with an auger, vertical wood piers are dropped into the holes, rebar is threaded through the wood piers and through a trench for a continuous grade beam, and concrete is poured into the trench and holes. Houses elevated a full story should have holes dug at least 6' deep, but for lower houses a 4' hole usually suffices. (see Fig.6, opposite.) If the house must be elevated more than a full story, another foundation system may be more cost-effective and more stable.

Although auger cast piers are common for concrete systems or in more industrial settings, this wood pier system is not a common one, and houses elevated 8' or more require a foundational depth that uses a significant amount of concrete. Nevertheless, if a homeowner has access to the equipment or has a remote site not accessible to pile drivers, this foundation may be an option.

INSTALLATION

Construction Process: Timber is brought to the site and holes dug with an auger as per a foundation plan. A concrete pad is dropped to the required depth in each hole to temporarily hold the pier. A continuous grade beam is dug to connect each pier hole, and rebar is threaded through each pier and along the grade beam, linking the entire system with steel.

The rebar and grade beam link each post together. Note that if the grade beam and rebar steel are omitted, this system becomes very unstable, and the house will not settle as one unit, which will cause serious structural problems over time.

Piers must be carefully held plumb and square to each other, as they cannot be moved once the concrete is poured. After the concrete sets, the temporary bracing can be removed and the rim joist can be bolted to the piers just as in driven wood pile construction.

Speed of Construction: Accurate rebar detailing and sufficient depth of pier holes must be achieved and inspected before concrete can be cast. The wood piers must be carefully squared and held in place. Allow a minimum of a week for construction, excluding concrete curing.

Delivery Method: Timber can be delivered or brought from lumber yards; rebar delivered from construction supply stores; and concrete can be brought on a truck in loads.

Required Equipment: An auger to dig; rebar benders; standard concrete and formwork tools.

Specialized Labor: Workers should be familiar with rebar and concrete, but no specialized labor is required, which is the main benefit of this foundation system.

PERFORMANCE

Wind Load: Piers are securely held in the ground, but as the structure is elevated, some sway will result. A good



(Fig.5) The wood piers are placed on site and connected with a concrete grade beam. Once the concrete is set, the bracing can be taken away and work on the floor framing can begin.

rule of thumb: if the house is elevated fewer than 6' above grade, 8x8 posts may be used; more than 6' above grade, 10x10 piers should be used. The extra size of 10x10 piles stiffens the pile against wind sway. Additionally, the posts should be cross-braced to resist racking.

Water Resistance: CCA-treated wood piles are resistant to water damage, flood scour, and rot. No other form of treatment should be used.

Energy/Thermal: No special thermal performance.

Life Span: CCA-treated wood piles are usually warranted for 40 years. If the rebar and grade beam are detailed precisely, the foundation should not settle unevenly.

Common Failure: Failure to observe engineered rebar placement and concrete depth specifications will result in differential settlement. As long as care is taken in these elements, the foundation should remain sturdy.

DESIGN

Environmental Impact: CCA treatment is toxic but is present in low enough quantities to not affect nearby soil or water. Timbers may be procured from a renewable, responsibly managed source. Concrete is not a renewable resource like wood. A small amount of flyash, a waste byproduct of coal mining, can be incorporated into the concrete mix. Flyash improves workability and also helps reduce corrosion from salt air and moisture.

Versatility / Flexibility: Wood piers with a concrete grade beam can be used for housing elevated to

a standard 18" crawlspace, or as high as 8' above grade. Doubled 2x12 rim joists bolted to 10x10 posts can span 10' comfortably. House plans should align posts for simpler floor framing construction.

Market Exposure: This is not a common foundation system, especially compared to all-concrete or driven wood pile systems.

Code Approval: As this is not a common foundation system, builders should check with their local building officials for approval considerations.

Affordability: The extensive concrete needed for the grade beam and the pile holes makes this a more expensive system than simply driving piles. However, if the homeowner is building this foundation himself, or if he has access to an auger, the savings in labor can offset the cost.

GULF COAST AVAILABILITY / LOCAL MANUFACTURERS

This unusual hybrid system is not commonly used. No local builders have been identified, but homeowners interested in this system should feel free to contact contractors with this research.

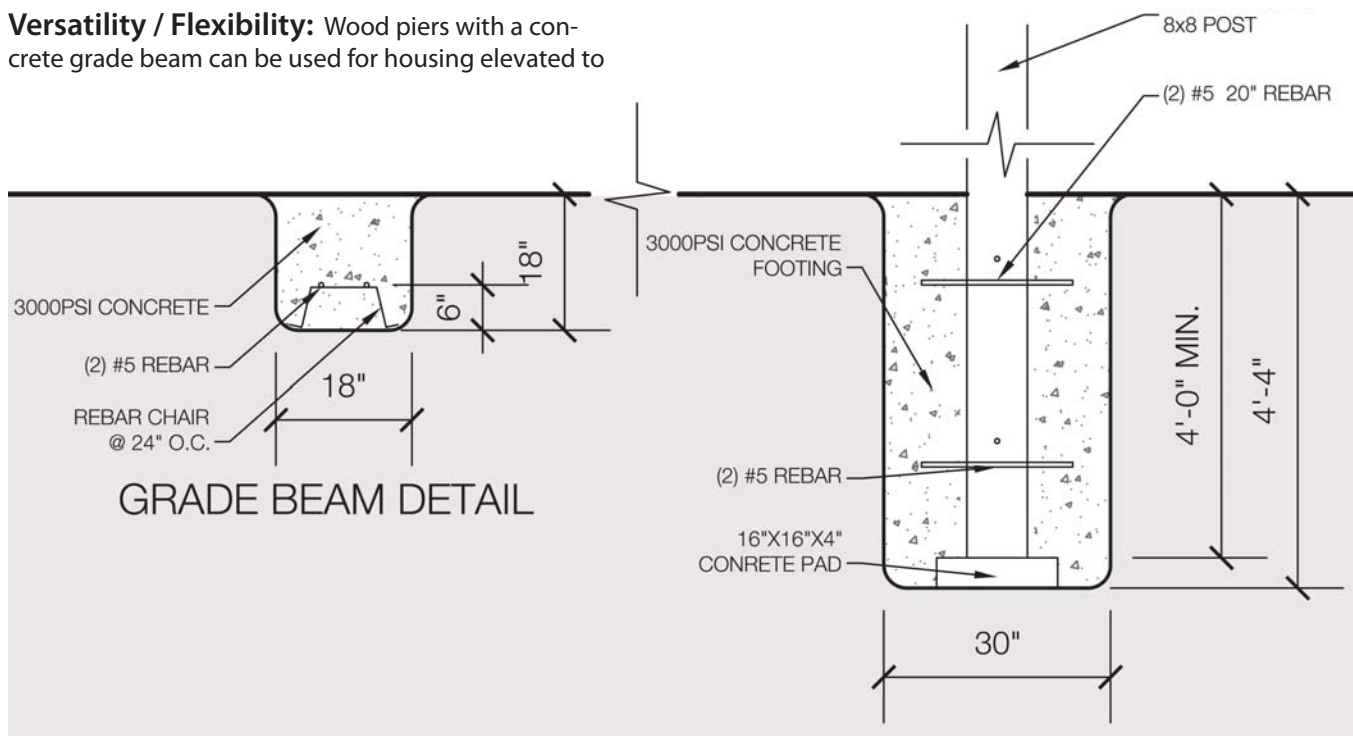

(Fig.6) Wood piers with a concrete grade beam are set by digging out a larger hole around each post, bearing the pier on a concrete pad at the bottom of the hole, and then filling the hole with concrete. The grade beam connecting each wood pier is an essential element, and will keep the house from settling unevenly.

Concrete Masonry Unit Piers

Overview: Concrete masonry units (CMU) are modular, stackable concrete blocks that can be stacked in piers to the required finished elevation. Professional masons lay the units on top of one another with intermediate layers of mortar; steel rebar is run vertically through the cavity; and the cavity is filled with grout.

Each pier bears on a continuous concrete footing below the soil. Anchor bolts are placed into the concrete at the top of the pier and then bolted securely to a continuous wooden sill and rim joist. This securely fastens the floor framing system to the foundation and pier system. 16 x 16 CMU blocks should be used to maximize hurricane resistance. Taller elevations may require the use of 24 x 24 CMU blocks for added stability.

FEMA recommends CMU piers up to a height of 8' above grade,⁴ but GCCDS strongly recommends a maximum CMU pier height of 4' above grade, to reduce the risk of failure due to lateral and uplift forces.

INSTALLATION

Construction Process: This is a fairly straightforward system for workers with concrete and masonry skills, but requires professionals. Absolute accuracy is required when the anchor bolts are placed.

The trenches are dug and formwork laid for the continuous concrete footing. The required rebar is formed and concrete cast in place around it. Once the continuous concrete footing is set, the masonry units are built up and linked into the footing with vertical rebar.

The cavities are filled with concrete as the pier is built up. The sill plates and anchor bolts should be accurately placed for tying into the floor system.

Speed of Construction: The continuous concrete footing must be formed, have steel rebar bent and laid in,

and poured before the construction on the CMU piers can begin. Once the piers are in place, they need to be filled and the anchor bolts placed accurately. Allow 4-5 days, including a foundation inspection before concrete can be poured.

Delivery Method: Concrete trucks drive to the site to pour the concrete for the footing and the CMU cavities. CMU can be purchased and delivered from nearly any lumber yard.

Required Equipment: Contractors need rebar benders, supplies for laying masonry, and a plastic vapor shield to control moisture below the continuous concrete footing. A concrete truck must be able to access the site.

Specialized Labor: Masons and skilled concrete workers.

PERFORMANCE

Wind Load: CMU piers, when using 16 x 16 blocks that are filled and reinforced, are resistant to lateral wind load, but not as strong as wood piles in resisting uplift. FEMA discourages CMU piers for elevations over 8' above grade, as lateral loads become too great and the structure is too rigid to absorb sway without cracking.

Water Resistance: CMUs are a porous concrete that can wick moisture. Flashing at the top of piers helps keep water from entering the pier and keeps termites from moving up the piers into the subfloor. CMU can also be sealed in order to keep moisture out, but the blocks

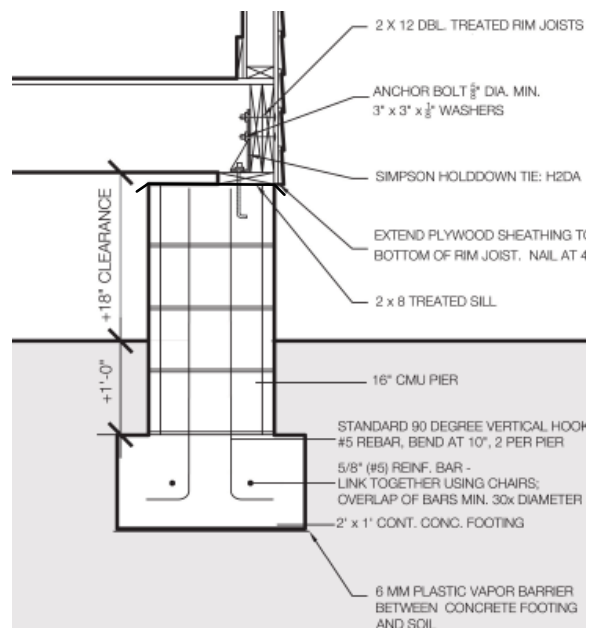

(Fig.7) Detail drawing of CMU pier on continuous concrete footing with sill connection.

must be completely dry before sealant is applied. FEMA strongly advises using extra care while building the foundation so high coastal winds, moisture, and salt air cannot penetrate cracks and seams.

Energy/Thermal: No special thermal performance.

Life Span: If filled and stacked correctly, with the proper mortar and steel, CMU piers will last 30-40 years.

Common Failure: If there is not enough rebar in the filled cavity of the CMU piers, wind uplift can pull insufficiently-mortared blocks apart. If cavities are not filled, lateral wind forces can push on the piers and break them at mortar seams. The steel bolted connection between the pier and the rim joist must be installed precisely according to manufacturers' specifications, or uplift may pull the floor platform off the piers.

DESIGN

Environmental Impact: CMU and concrete are not renewable resources like wood. A small amount of flyash, a waste byproduct of coal mining, can be incorporated into the concrete mix. Flyash improves workability and also helps reduce corrosion from salt air and moisture.

Versatility / Flexibility: CMU piers are well-suited to coastal vernacular styles as long as houses are not elevated very high. Tall CMU piers below houses are not common and seem out of character. Some homeowners find the appearance of exposed CMU unattractive and plant or screen the underside of the house.

Building on point-loaded piers as opposed to a slab or stem wall requires the floor platform framing system to be designed on a regular module to simplify the framing.

Market Exposure: CMU is readily available and visible throughout the Gulf Coast. High-elevation CMU foundations are rarer than a standard crawlspace height, but are increasingly common.

Code Approval: Local building officials should approve CMU piers if they incorporate appropriate thickness and number of rebar per pier, appropriate concrete mix, and plastic vapor barrier below the continuous footing.

Affordability: CMU is an inexpensive material, and steel rebar is affordable. The concrete required for the continuous footing, as well as the masonry labor costs, make this foundation system generally more expensive than wood piles.



(Fig.8) The CMU piers should be laid by experienced masons to ensure the foundation is square and can resist lateral wind forces.

GULF COAST AVAILABILITY / LOCAL MANUFACTURERS

This is a fairly common residential foundation type in the Gulf Coast region, and most contractors should be able to easily construct both the concrete continuous footing and the CMU piers. Foundations of houses elevated significantly above grade should be constructed by specialty contractors who are experienced with elevated housing.

Any homebuilding supply store will be able to supply CMU and materials for the concrete footing, and can special order any steel connections for the rim joists.



(Fig.9) Elevating houses a full story on CMU piers is discouraged due to susceptibility to lateral wind forces.



(Fig.10) The steel connection from the rim joist to the top of the CMU pier should be accurately placed for ease of framing.

Stem Walls - CMU

Overview: Stem walls, sometimes known as chain walls, are continuous foundation walls constructed of concrete masonry units (CMU) - modular concrete blocks that are stacked to the required finished elevation. The walls are constructed by professional masons, and steel rebar is embedded inside the cavity with a concrete grout.⁵ The walls bear on continuous concrete footings below the soil. Anchor bolts are placed at the top of the walls every 12" and bolted securely to a continuous wooden sill and rim joist, thereby securely fastening the floor platform framing system with the foundation and pier system. In some cases if the stem wall is low enough, the entire interior is backfilled, and a slab is poured across the surface.

If building in a flood zone, the stem wall must incorporate regularly spaced flood vents. Stem walls are not appropriate for houses requiring an elevation of over 8'. Stem walls are not appropriate for houses in coastal A or V Zones due to scour and undermining of their relatively shallow foundations in the case of a storm surge.⁶

INSTALLATION

Construction Process: This is a fairly straightforward project for workers with concrete and masonry skills. Anchor bolts should be placed very accurately. A footing is dug and poured with the proper rebar configuration; the CMU is laid and mortared by professional masons; and the CMU cavities have rebar installed before they are filled with concrete (sometimes called grout). Anchor bolts are placed into the grouted cavities to connect to the pressure-treated sill plate, making sure not to conflict with the framing layout to be constructed afterwards.

If a slab is being poured, the system is backfilled with fill or gravel before the slab is formed and poured. If the floor is constructed of an open floor framing system bearing on the perimeter CMU walls, the rim joist is securely connected to the sill plate, which is anchored to the wall.⁷

Speed of Construction: Before the piers can be built, the continuous concrete footing must be formed and poured with the steel rebar bent and laid in. Once the piers are in place, the cavities must be grouted and the anchor bolts accurately placed. This foundation should take no longer than a week, including a foundation inspection.

Delivery Method: Concrete trucks can drive to the site to pour concrete for the footing and cavity fill. CMU can be purchased and delivered from nearly any lumber yard.

Required Equipment: Contractors need rebar benders, masonry supplies, and a plastic vapor shield to control moisture below the continuous concrete footing. A concrete truck must be able to come to the site.

Specialized Labor: Skilled concrete workers and masons.

PERFORMANCE

Wind Load: Stem walls must resist a much heavier wind load than individual piers, due to their long, broad walls. When CMU cavities are filled and rebarred properly, with anchor bolts in place, they resist uplift well.

Water Resistance: CMU is made of porous concrete that can wick moisture. Flash walls at the top, both to keep out moisture and to resist termites. CMU can also be sealed in order to keep moisture out, but the blocks should be fully dry before applying sealant so moisture is not trapped inside. FEMA strongly advises using extra care while constructing CMU foundations so high coastal

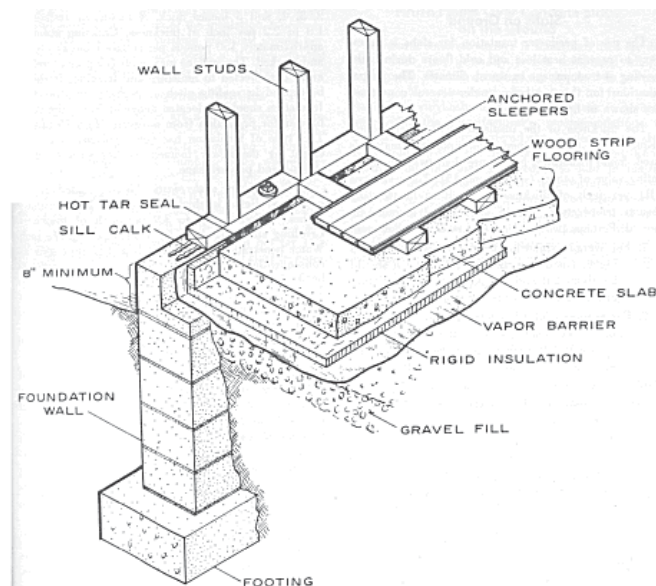

(Fig. 11) A stem wall can either have an open framing platform between its perimeter walls, or can be backfilled, as in this drawing. A concrete slab can then be poured on top of the fill, so no floor framing system is needed.

5.4 | Stem Walls

winds, moisture, and salt air cannot penetrate cracks and seams.⁸

Energy/Thermal: No special thermal performance.

Life Span: If filled and stacked correctly, with the proper mortar, CMU walls should last 30-40 years.

Common Failure: If there is not enough rebar in the filled cavity of the CMU, wind uplift can pull insufficiently-mortared blocks apart. If cavities are not filled, lateral wind forces can push on the walls and cause failure at mortar seams. The steel bolted connections from the walls to the sill plates must be installed precisely according to manufacturers' specifications, or uplift may pull the floor platform off the wall.

DESIGN

Environmental Impact: CMU and concrete are not renewable resources like wood. A small amount of flyash, a waste byproduct of coal mining, can be incorporated into the concrete mix. Flyash improves workability and also helps reduce corrosion from salt air and moisture.⁹

Versatility / Flexibility: Homeowners often find the appearance of exposed CMU unattractive. Continuous stem walls are not as suited to local vernacular houses and character as individual piers. Often stem walls are covered with a brick or a stone facade to give the home a more pleasing appearance.

If the stem wall is backfilled and a slab poured, there are no special design considerations for floor framing, as walls are constructed directly on top of the slab. If a floor platform is constructed across the exterior walls, the foundation should be as rectilinear as possible in order to simplify the floor framing system.

Market Exposure: CMU is readily available and widely used along the Gulf Coast. Low stem walls are common, but may be associated with lower income developments. Nevertheless, finding masons or concrete workers who can readily do the work should be easy.

Code Approval: Local building officials should approve stem walls if they incorporate appropriate thickness and number of rebar, appropriate concrete mix, and plastic vapor barrier below the continuous footing. Stem walls may not be allowed in historic districts or other neighborhoods, with design guidelines.

Affordability: CMU is an inexpensive material, and steel rebar is affordable. The concrete required for the continuous footing is the most expensive part of this foundation system. Professional mason labor can be expensive.

GULF COAST AVAILABILITY / LOCAL MANUFACTURERS

This is a very common residential foundation type throughout the United States, and most contractors should be able to easily construct both the concrete continuous footing and the CMU walls. Foundations of houses elevated significantly above grade should be constructed by specialty contractors who are experienced with elevated housing.

Any homebuilding supply store will be able to supply CMU and materials for the concrete footing, and can special order any steel connections for the rim joists.



(Fig.12) Stem walls in flood zones have special venting requirements. Consult local code officials for specifics.

Poured Concrete Piers

Overview: Concrete piers are a cast-in-place pier system in which each pier bears on a continuous below-grade concrete footing (if elevated fewer than 10'); or extends deep into the soil, connected by means of a continuous grade beam or slab (if elevated 10' or more). Round cardboard tubes are often used as formwork and torn off after the concrete cures. Other types of formwork, such as reusable square plastic tubes, metal, or a conventional wood formwork can be used as well.¹⁰

A related system employs the footing or grade beam and the concrete piers, but uses piers that only extend part of the way out of the ground - often a foot or two - with a wood post bolted on top of the pier, to extend up to the floor system. If this system is used, the wood posts must either extend up through the walls of the house, or be heavily cross-braced, in order to resist lateral forces. The concrete-to-wood connection must also be designed carefully to resist overturning forces.

A poured concrete pier system with a continuous grade beam or slab, with concrete piles extending deep below the soil, is very strong and can be used on houses elevated to heights other foundation systems cannot support. However, the large quantities of steel and concrete required for such a system make it considerably more expensive than other systems. If the homeowner is in a V-zone or coastal A-zone, or is required to build more than 10' above grade, this system may justify the additional cost.

INSTALLATION

Construction Process: As this system is more often utilized for highly elevated houses, it requires precision and skill, and a great deal of material. However, the system is buildable by a skilled concrete and steel worker.

In the case of a continuous footing with piers above, the

footing is dug and steel laid before concrete is poured, with vertical steel bars protruding at the location of each pier. Once the footing is set, the piers can be formed and poured, using the rebar to join them to the footing.

In the case of deep piers with a continuous grade beam, holes are dug for the piles, usually with an auger. Steel is laid in, with steel placed to form connections to the future grade beam and above-grade piers. The below-grade piers are then poured, followed by the above-piers.

In both foundation depths, the steel connections must be accurately placed into the concrete piers to securely connect the foundation system to the floor framing system.

Speed of Construction: Each element of this foundation system must be accurately in place and set before the next element can be added. As a result, the foundation will take a minimum of one week to build.

Delivery Method: Rebar is available at any lumber yard or home supply store and can be delivered on-site. Concrete is delivered by concrete mixing truck to the site to pour in place. Any special steel connections may need to be special ordered.

Required Equipment: Standard concrete tools: rebar benders, concrete tools and concrete vibrator. Deep con-



(Fig.13) Poured concrete piers can be cast in many forms, and at many heights, making this a very versatile foundation choice for storm and flood zones.

5.5 | Poured Concrete Piers

crete pile foundations require an auger as well.

Specialized Labor: Skill with concrete and steel. Workers should be experienced foundation contractors.

PERFORMANCE

Wind Load: With proper steel reinforcement through each pier and the continuous footing/grade beam, and proper bolting to the floor system, a poured concrete pier foundation system will resist both lateral and uplift forces.

Water Resistance: FEMA recommends casting concrete in place with a minimum of 3" of cover over all steel in order to protect the steel from corrosion of salt moisture.¹¹ The concrete mixer should use a concrete with a minimum compressive strength of 3000 psi, as increased water in the mix increases the chance of cracking and moisture penetration.

Energy/Thermal: No significant thermal benefits.

Life Span: When detailed and constructed according to proper details, a concrete foundation system will last upwards of 40 years.

Common Failure: The joints will be the weak point of a properly detailed concrete system. Ensure that steel is properly installed throughout formwork, including any anchor bolts or wood-post connections.

Wood post connections are susceptible to racking in high lateral winds if not properly braced. For the best lateral-load resistance, extend posts up through the walls of the

house above, or at minimum on the corners. This harnesses the resistance of the entire structure against winds.

DESIGN

Environmental Impact: Concrete is not a renewable resource like wood. A small amount of flyash, a waste byproduct of coal mining, can be incorporated into the concrete mix. Flyash improves workability and also helps reduce corrosion from salt air and moisture.¹²

Versatility/Flexibility: Concrete can be used for all elevation heights, and can be varied in its finish to allow for homeowner preferences. Homeowners can choose rectangular piers or round ones, and whether to bring the concrete up to the rim joist or to make a connection with a wood post.

The house should be designed so that piers align with rim joists to simplify the floor platform framing system.

Market Exposure: Concrete foundation systems are ubiquitous along the Gulf Coast, in both residential and commercial applications.

Code Approval: Research local building codes regarding reinforcing steel thicknesses and lengths. Foundation inspections are required before concrete is poured. City officials are likely to approve a well-executed and conservatively engineered system.

Coastal Considerations: Poured concrete piers are an exceptionally good choice for high-velocity flood zones or for zones requiring houses to be elevated high above



(Fig.14) This house is a good example of poured concrete piers using a square formwork, as opposed to round.



(Fig.15) Concrete can also be poured part way to the finished floor, with bolted wood posts making up the remaining distance.

grade. When detailed properly, the steel will not corrode. When the proper amount of steel is used, and the connections detailed properly, this system should resist hurricane-strength winds and flooding.

Affordability: Concrete is more expensive than wood, especially with a grade beam or footing, or when a house is elevated especially high above grade. Some systems may cost 150% - 200% more than a driven wood pile system.¹³

Poured concrete systems use significant amounts of steel and concrete. Still, the additional cost may be justified, especially if the house is elevated above 10', or if annual insurance premiums can be lowered significantly (see Appendix I).

GULF COAST AVAILABILITY / LOCAL MANUFACTURERS

This is a fairly common residential foundation type on the Gulf Coast and homeowners should easily find contractors. However, foundations of houses elevated significantly above grade should be constructed by specialty contractors who are experienced with elevated housing.



(Fig.16) Connections between concrete piers and wood posts should be placed accurately for ease of framing.

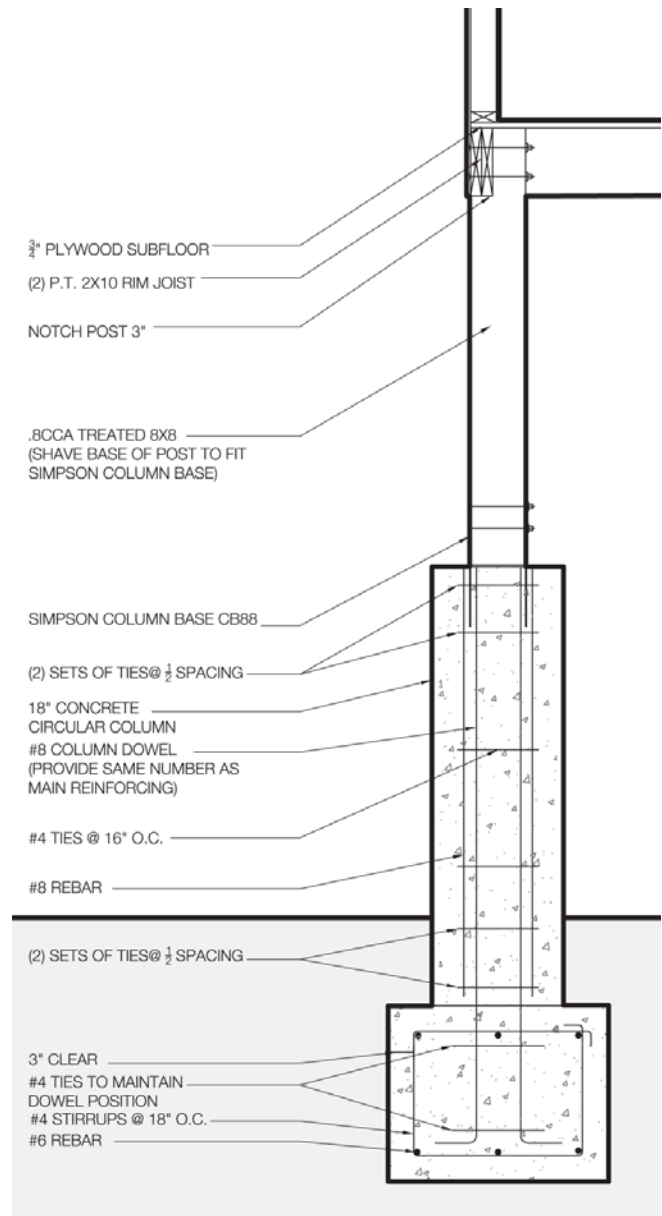

(Fig.17) Detail drawing of a poured concrete pier on a continuous concrete footing, with a bolted wood post connecting to the rim joist.



(Fig.18) Round cardboard tubes are a common, simple, and fast formwork for piers.